

# MODEL EB12 EXTERNAL BLOWER

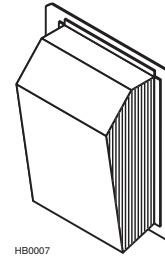

HB0007

Use this high-powered ventilator to quietly and efficiently exhaust airborne contaminants from cooking and living space.

### FEATURES:

- Brushed aluminum construction
- Built-in flashing plate for roof or wall mount
- Built-in backdraft damper and birdscreen
- Easily removable cover provides quick access to blower for cleaning and servicing
- For 10" round duct
- Thermally protected, permanently lubricated, ball-bearing motor
- Speed control compatible motor
- Dynamically balanced 14" diameter backward-curved impeller
- Low RPM - quiet operation
- For use with Best hoods and downdrafts designed to use external blowers

### SPECIFICATIONS

<b>VOLTS</b>	120
<b>AMPS</b>	3.0
<b>CFM</b>	1200
<b>DUCT</b>	10" Round

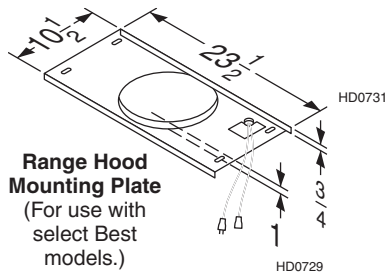
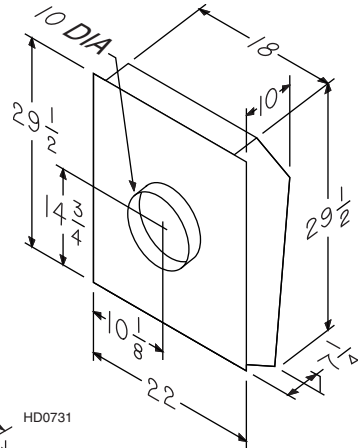

**Range Hood Mounting Plate**  
(For use with select Best models.)

HD0729



HG0087A

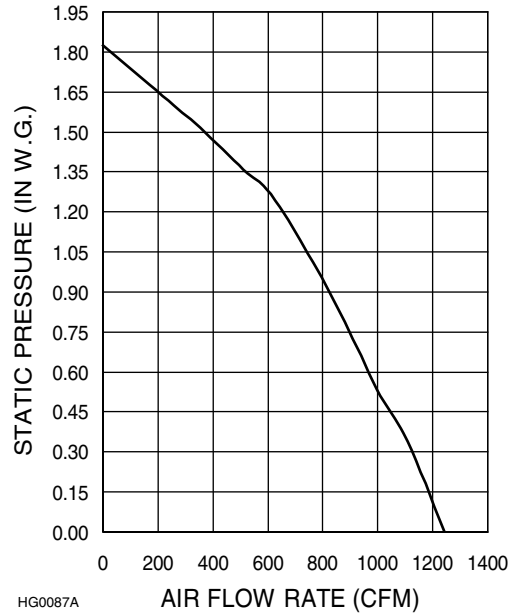

HVI-2100 CERTIFIED RATINGS comply with new testing technologies and procedures prescribed by the Home Ventilating Institute, for off-the-shelf products, as they are available to consumers. Product performance is rated at 0.1 in. static pressure, based on tests conducted in a state-of-the-art test laboratory. Sones are a measure of humanly-perceived loudness, based on laboratory measurements.

NOTE: DIMENSIONS SHOWN ARE IN INCHES

BEST Drummondville, QC Canada [www.BestRangeHoods.ca](http://www.BestRangeHoods.ca) 866-737-7770

REFERENCE	QTY.	REMARKS	Project
			Location
			Architect
			Engineer
			Contractor
			Submitted by <span style="float: right;">Date</span>